

ENGINEERING SHEET	TITLE	RKC32 Residual Current circuit Breaker with Overload protection (RCBO) SPECIFICATION	CODE	WORK CODE
--------------------------	-------	---	------	-----------

Technical data

Type	RKC32
Protection	Ground fault & Overload
Rate current	6, 10, 16, 20, 25, (32)A
Operating IΔn	30mA (Non-adjustable)
Characteristics	C curve
Non-Operation IΔN	0.5 IΔN
Number of poles	1P+N
Rated voltage	240VAC 50Hz
Residual current off-time	≤ 0.01 Sec
Standards	IEC61009
Approval	SEMKO CB sheme
	มฉก. 909-2548
	CE marking
Type of trip ground fault	
Ground fault	Electronics
Overload	Thermal - magnetic
Breaking capacity	6, (4.5)kA
Rated making capacity (Im)	2000A
Electrical endurance	4,000 operations
Installation	35mm DIN rail
Width	17.8mm
Type of terminal	Lug type (Cable up to 10mm ²)
Alam switch (option)	Not applicable

Tripping characteristics

Type C:
 - Instant tripping characteristics: 5 - 10In
 - Application: General load such as bulbs, motors

Dimension

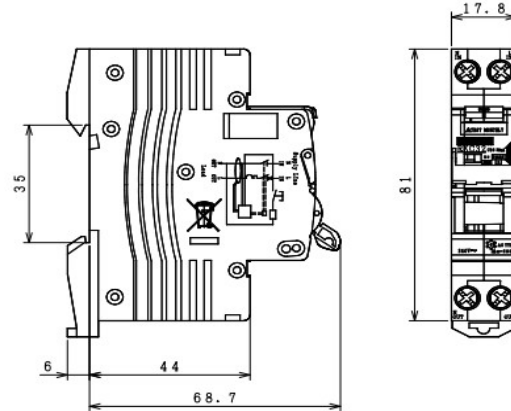

Characteristic curve and compensation curve

Operating curve

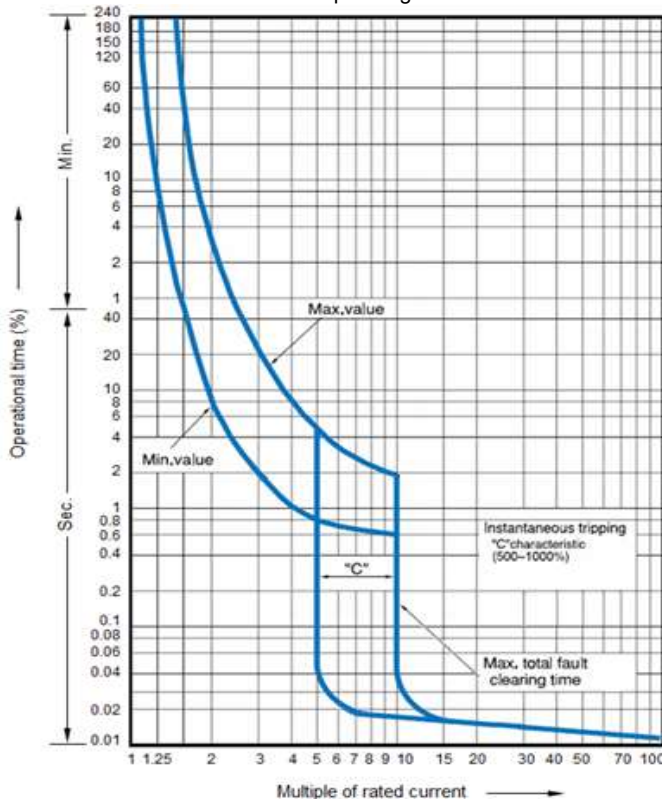

Compensation table

[Temperature compensation table](IEC60898-1)

In(A)	20°C	25°C	30°C	35°C	40°C	45°C	50°C	55°C	60°C
1	1.05	1.02	1.0	0.98	0.95	0.93	0.9	0.89	0.85
2	2.03	2.04	2.0	1.96	1.92	1.88	1.84	1.8	1.74
3	3.18	3.09	3.0	2.91	2.82	2.7	2.61	2.49	2.37
4	4.24	4.12	4.0	3.88	3.75	3.64	3.52	3.36	3.24
6	5.24	6.12	6.0	5.88	5.76	5.64	5.52	5.4	5.3
10	10.6	10.3	10.0	9.7	9.3	9.0	8.6	8.2	7.8
16	16.8	16.5	16.0	15.5	15.2	14.7	14.2	13.8	13.3
20	21.0	20.3	20.0	19.4	19.0	18.4	17.8	17.4	16.8
25	26.2	25.7	25.0	24.2	23.7	23.0	22.2	21.5	20.7
32	33.5	32.9	32.0	31.4	30.4	29.8	28.4	28.2	27.5
40	42.0	41.2	40.0	38.8	38.0	36.8	35.6	34.4	33.2
50	52.5	51.5	50.0	48.5	47.4	45.5	44.0	42.5	40.5
63	66.2	64.9	63.0	61.0	58.0	56.7	54.2	51.7	49.2

[1:113%In 12:145%In according to IEC60898-1]

Compensation curve

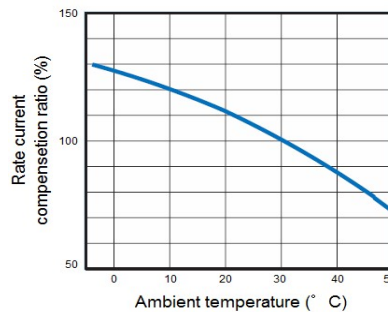

KEY WORD					MS-WORD		
DWG.	O.SITTICHAJ	17-May-21	REGD 2021-05 17	DWG No.	SH.	REV.	
CHKD.	C.CHONTICHA	17-May-21		4HTN001302	1		
CHKD.	M.SOMKIAT	17-May-21			1	00	
APPRD.	S.SUGAI	17-May-21					