

HITACHI ELECTROMAGNETIC SWITCH

Type	Rated insulation voltage (Ui)	Max. rated capacity of motor			Rated thermal current (AC1 = Ith)	Applicable standard	Aux. Contact	Weight
H300C-T	AC 660 V	240V	90kW	300A	350 A	IEC 60947-4-1	3a3b	13 kg
H300C-TK		440V	150kW	300A				

*WITH AUX. CONTACT 4 a 4 b = 199 mm.

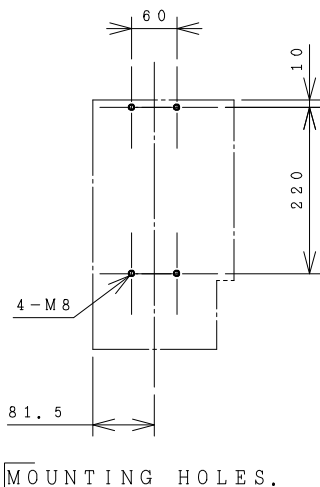
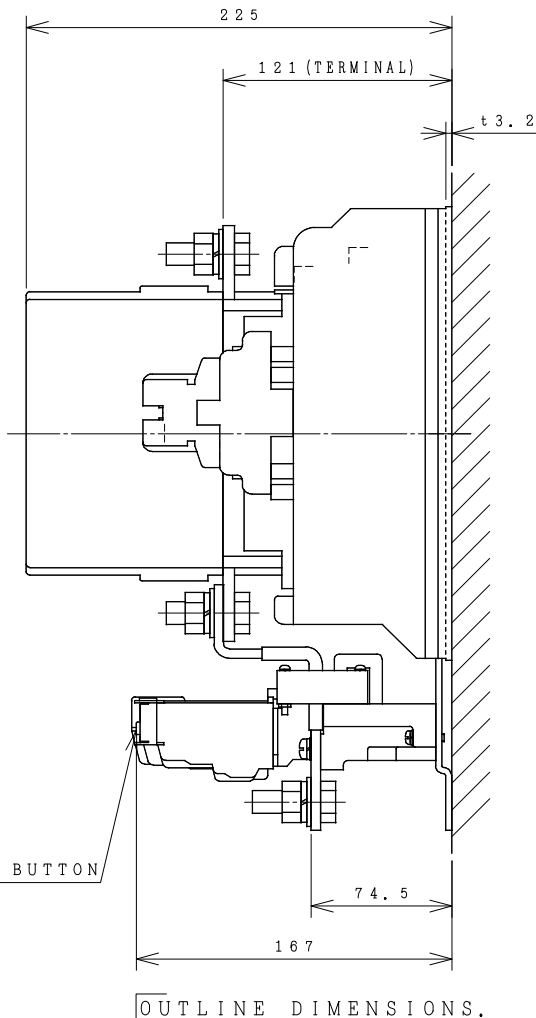
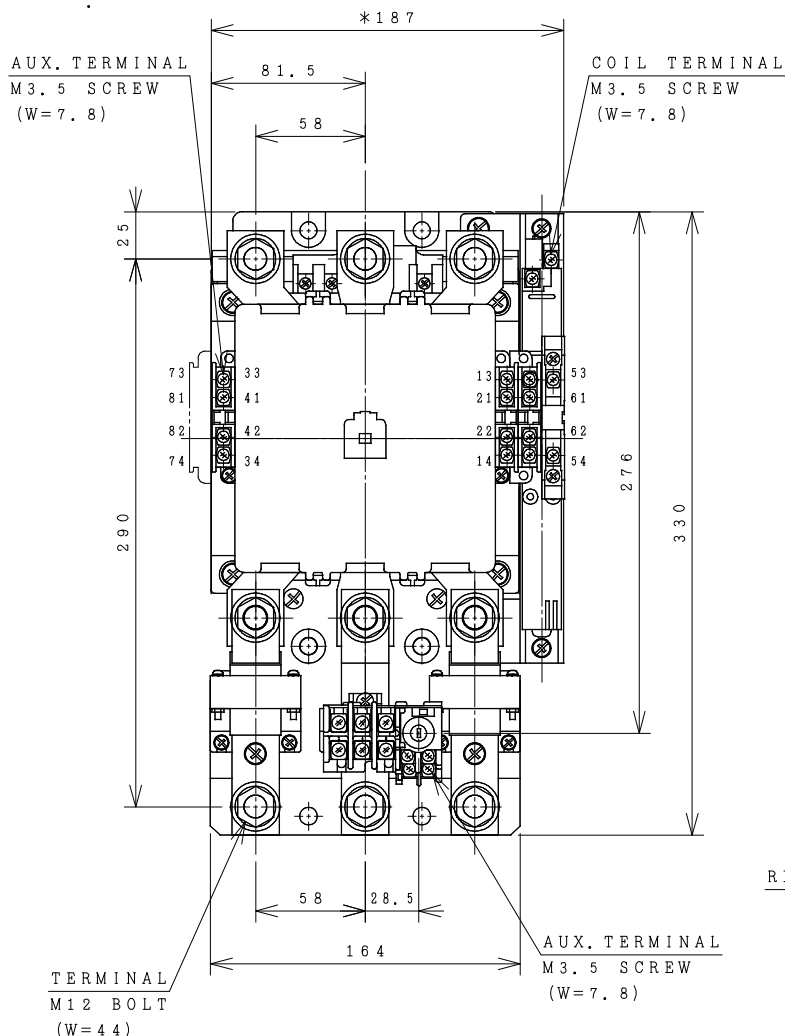

(W=) : WIDTH OF TERMINAL.

***REMARK**

- DIMENSION UNIT = Millimeter (mm.).
- (a) = AUX. CONTACT NORMALLY OPENED.
- (b) = AUX. CONTACT NORMALLY CLOSED.

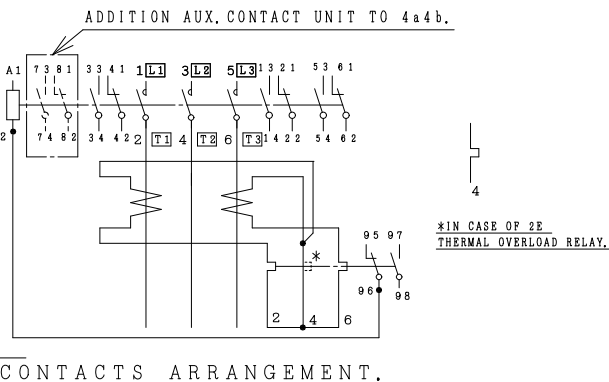

(Reference 43055994R02).

DWN. S. CHAIAMPOL CHKD. <i>Janaka</i> APPD. <i>T. Kiatissak</i>	30/08/16 S	PROJECTION 	TITLE DIMENSION OF H300C-T, TK
HITACHI Hitachi Industrial Technology (Thailand), Ltd.			HITT WORKS DWG. No. 4HTN000921
			REV. 00 SH. 01 01