

HITACHI ELECTROMAGNETIC SWITCH

| Type | Rated insulation voltage (Ui) | Max. rated capacity of motor | | | Rated thermal current (AC1 = I _{th}) | Applicable standard | Aux. Contact | Weight |
|-----------|-------------------------------|------------------------------|------|------|--|---------------------|--------------|----------|
| SH150C-T | AC 660 V | 240V | 45kW | 150A | 150 A | IEC 60947-4-1 | 2a2b | 13 kg |
| SH150C-TK | | 440V | 75kW | 150A | | | | |

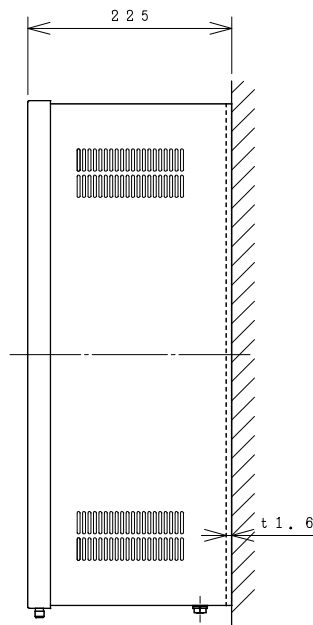

OUTLINE DIMENSIONS.

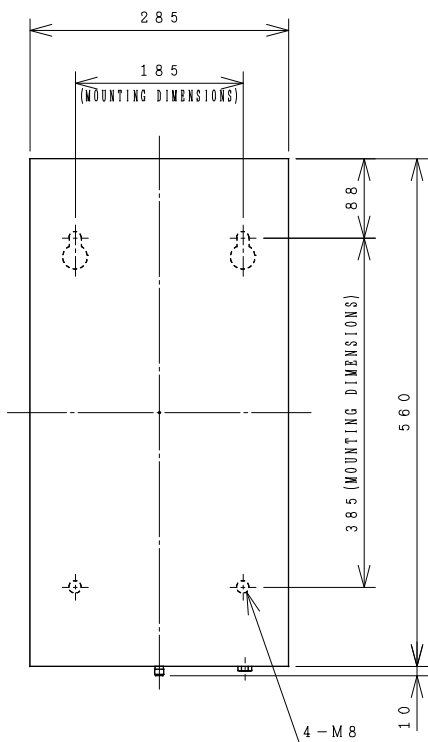
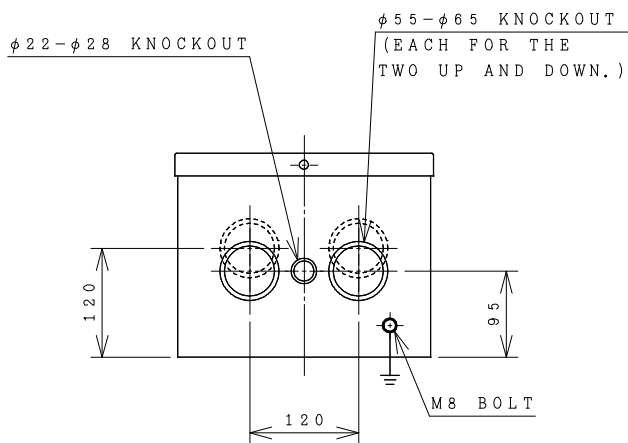

MOUNTING HOLES.

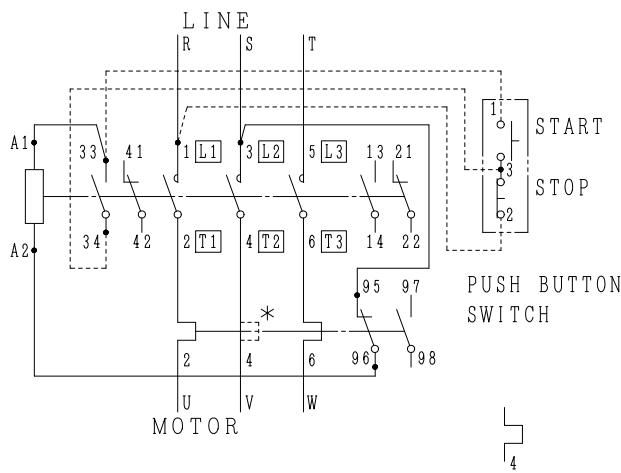

CONTACTS ARRANGEMENT.

IN CASE OF SE THERMAL OVERLOAD RELAY.

(Reference 43063966R01).

REMARK

- DIMENSION UNIT = Millimeter (mm.).
- (a) = AUX. CONTACT NORMALLY OPENED.
- (b) = AUX. CONTACT NORMALLY CLOSED.

| | | TERMINAL SCREW | WIDTH OF TERMINAL |
|-----------|----------------|----------------|-------------------|
| MAIN | CONTACTOR | M8 (BOLT) | 27 |
| CIRCUIT | OVERLOAD RELAY | M8 (BOLT) | 27 |
| OPERATION | CONTACTOR | M3.5 | 7.8 |
| CIRCUIT | OVERLOAD RELAY | M3.5 | 7.8 |

| | | | | |
|---|--------------------|----------|------------|---------------------------|
| DWN. | S. CHAIAMPOL | 26/08/16 | PROJECTION | TITLE |
| CHKD. | <i>Jan-a</i> | | | DIMENSION OF SH150C-T, TK |
| APPD. | <i>C.Kiattisak</i> | | SCALE | |
| | <i>Tokisudh</i> | | NTS. | |
| HITACHI Hitachi Industrial Technology (Thailand), Ltd. | | | | HITT WORKS DWG. No. |
| | | | | 4HTN000899 |
| | | | | REV. |
| | | | | 00 |
| | | | | SH. |
| | | | | 01 |
| | | | | 01 |