

HITACHI ELECTROMAGNETIC CONTACTOR

Type	Rated insulation voltage (Ui)	Max. rated capacity of motor			Rated thermal current (AC1 = Ith)	Applicable standard	Aux. Contact	Weight
		240V	11kW	40A				
HS35	AC 690 V	440V	18.5kW	40A	50 A	IEC 60947-4-1	2a2b	0.59 kg

※WITH AUX. CONTACT SIDE ON UNIT = 102mm.

※WITH AUX. CONTACT HAED ON UNIT = 119.5mm.

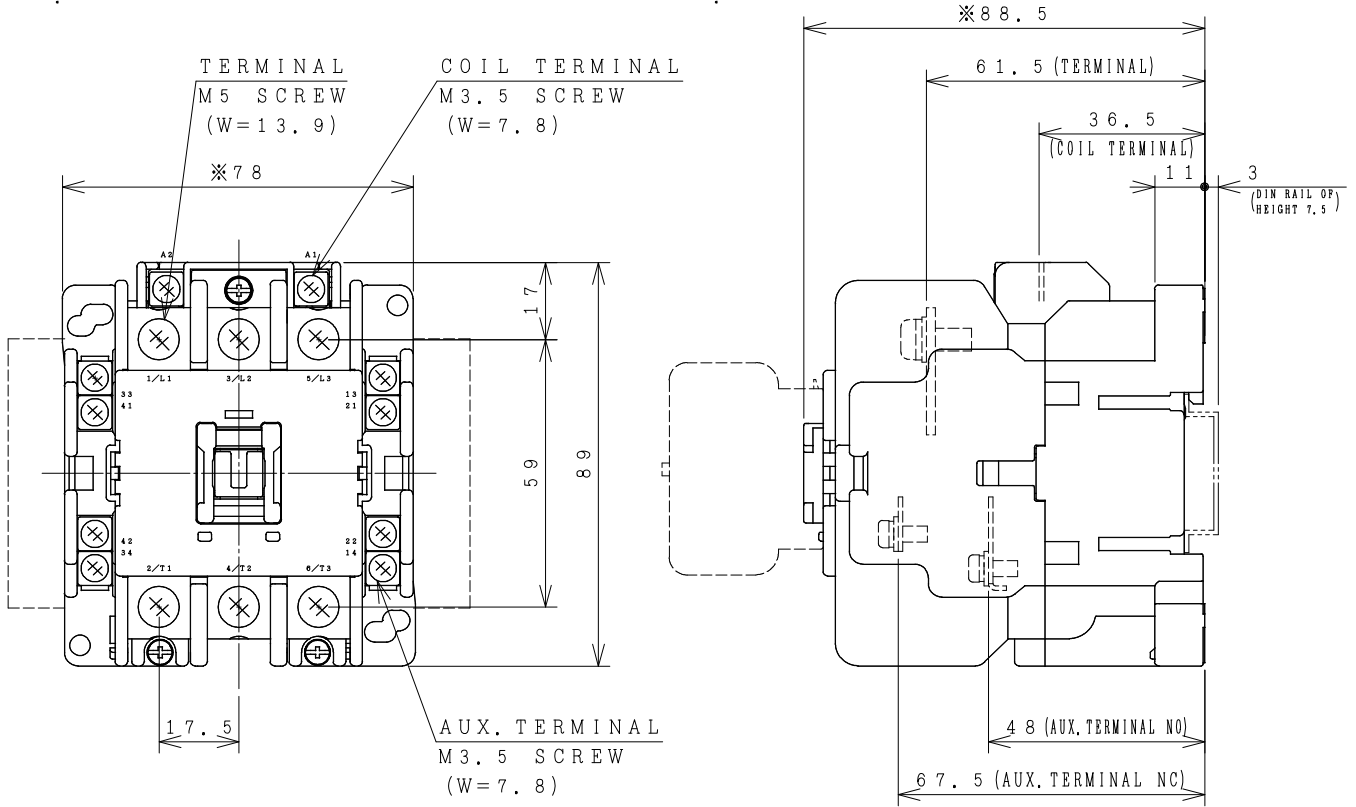

OUTLINE DIMENSIONS.

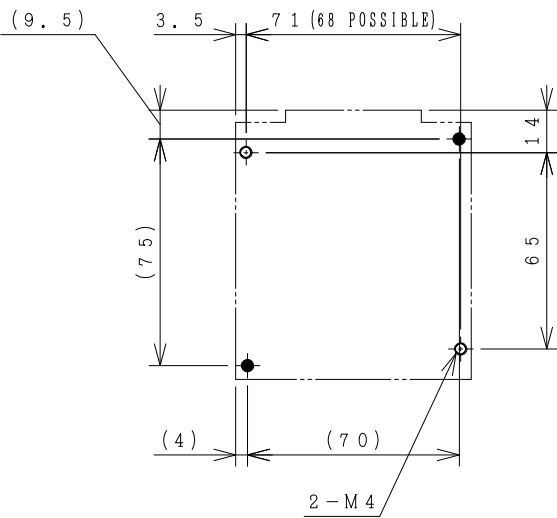

MOUNTING HOLES.

(60~) 65 x 70

(64~) 68 x 67

ALSO POSSIBLE.

(W=) : WIDTH OF TERMINAL.

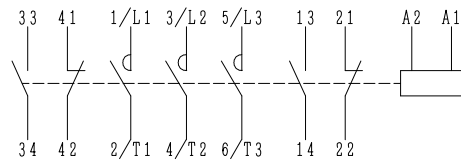

AUX. CONTACTS. : 2a2b
CONTACTS ARRANGEMENT.

(Reference 43067192R05).

※REMARK

- DIMENSION UNIT = Millimeter (mm).

- (a) = AUX. CONTACT NORMALLY OPENED.

- (b) = AUX. CONTACT NORMALLY CLOSED.

DWN. O. SITTICHAJ	04/08/16	PROJECTION	TITLE
CHKD. <i>C. Kiatissak</i>		SCALE	DIMENSION OF HS35
APPD. <i>T. Kiatissak</i>		NTS.	
HITT WORKS DWG. No.			REV.
HITACHI Hitachi Industrial Technology (Thailand), Ltd.			00
			01
			01

4HTN000820