

三相誘導電動機 THREE-PHASE INDUCTION MOTOR

出力 OUTPUT	形 TYPE	式 FORM	定 格 RATING	電 圧 VOLTAGE (V)	周波数 FREQ. (Hz)	同期回転速度 SYNC. SPEED (min ⁻¹)	極 数 POLES	耐熱クラス TH. CLASS	質 量 MASS (kg)
7.5HP	TFO	LKK	S1	380/415	50	3000	2	F	45
10HP	TFO	LKK	S1	380/415	50	3000	2	F	50
7.5HP	TFO	LKK	S1	380/415	50	1500	4	F	56
5HP	TFO	LK	S1	220/380	50	1000	6	F	50

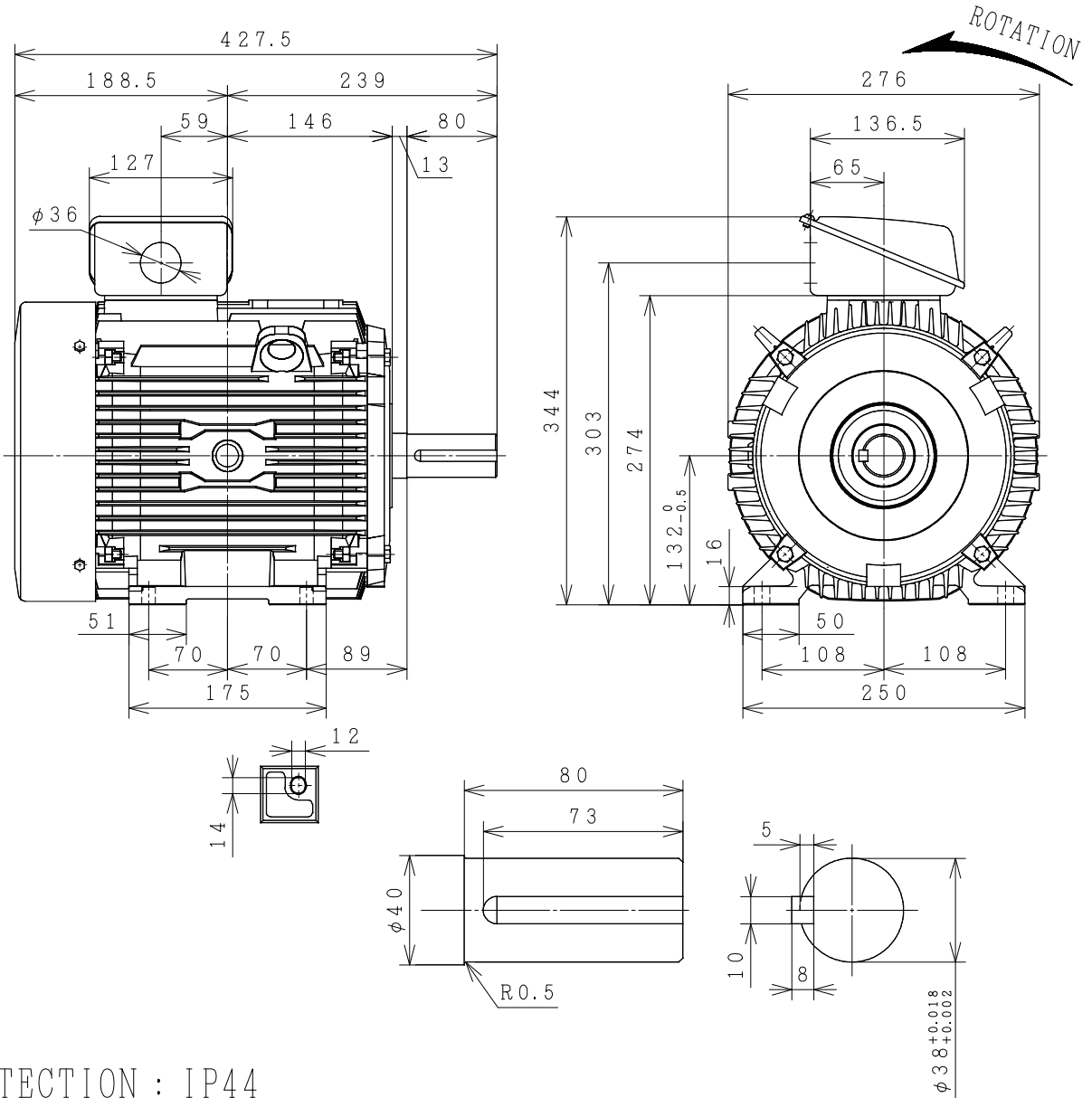

PROTECTION : IP44

保護方式 (PROTECTION)	塗装色 (COLOR)	軸受 (BRG.)	反負荷側 (O. S.)	負荷側 (D. S.)
用途 USE	付属品 ACCESSORY	御注文主 CUSTOMER	数量 QTY.	受注番号 ORDER NO.
備考 NOTICE	作業番号 WORK NO.	REV.		

DWN. S. WICHIAN	22-Mar-2016	寸 法 図 DIMENSIONS	HITACHI Hitachi Industrial Technology (Thailand), Ltd.	NARASHINO DWG. NO.	SH.
CHKD. P. Damrongsak				3244HTD03402	
APPD. K. KAIHATSU					

枠番 FRAME SIZE TFO L-132S (TMHD)