

三相誘導電動機 THREE-PHASE INDUCTION MOTOR

出力 OUTPUT	形 TYPE	式 FORM	定 格 RATING	電 圧 VOLTAGE (V)	周波数 FREQ. (Hz)	同期回転速度 SYNC. SPEED (min ⁻¹)	極 数 POLES	耐熱クラス TH. CLASS	質 量 MASS (kg)
40HP	VTFOA	LKK	S1	380/415	50	3000	2	F	215
40HP	VTFOA	LKK	S1	380/415	50	1500	4	F	245
25HP	VTFOA	LKK	S1	380/415	50	1000	6	F	215
30HP	VTFOA	LKK	S1	380/415	50	1000	6	F	235

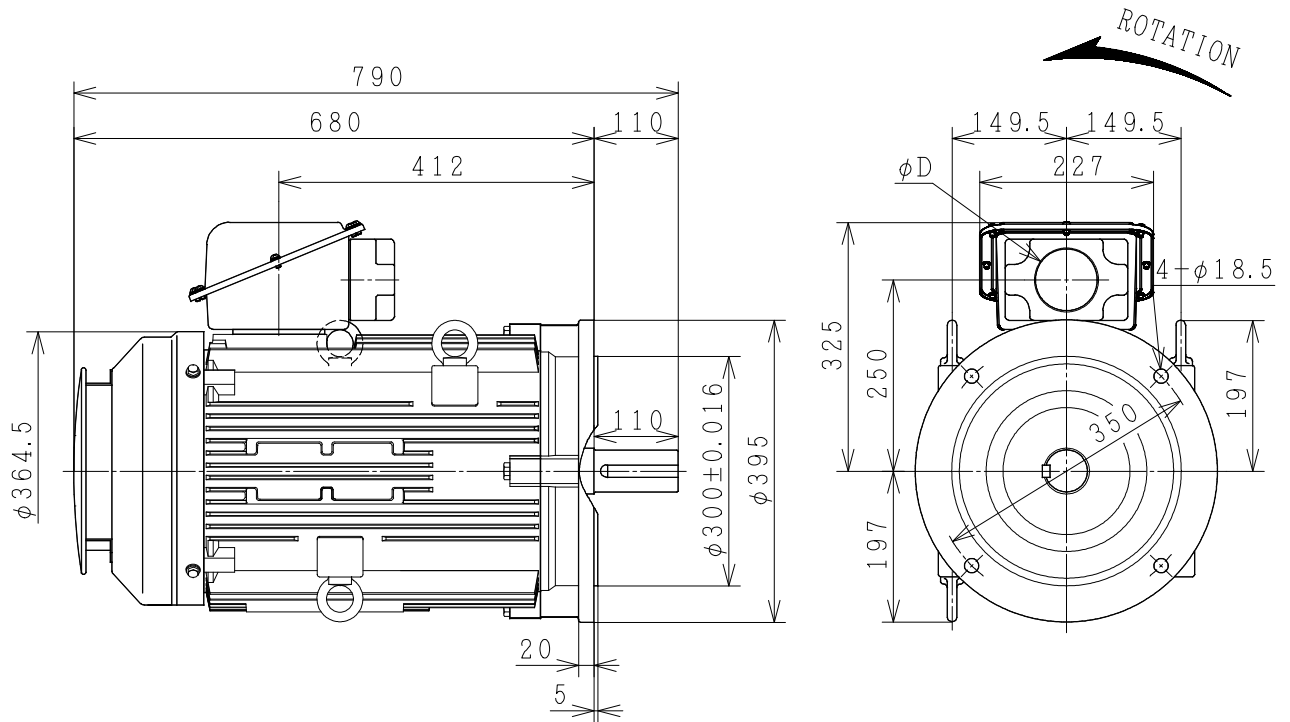

φD
PF1 1/4
PF1 1/2
PF2
PF2 1/2
PF3

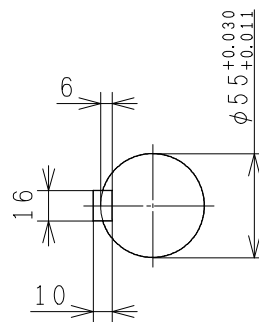
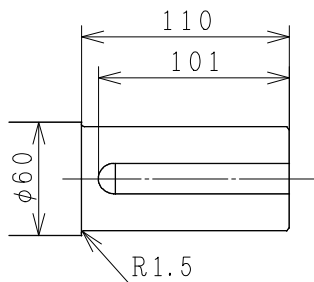

PROTECTION : IP55

保護方式 (PROTECTION)	塗装色 (COLOR)	
軸受 (BRG.)	反負荷側 (O. S.)	負荷側 (D. S.)

用途 USE _____ 付属品 ACCESSORY _____

備考 NOTICE

御注文主 CUSTOMER	数量 QTY.	受注番号 ORDER NO.	作業番号 WORK NO.	REV.
---------------	---------	----------------	---------------	------

DWN. C. Saknarin	05-Oct-2015	寸 法 図 DIMENSIONS	HITACHI Hitachi Industrial Technology (Thailand), Ltd.	NARASHINO DWG. NO.	SH.
CHKD. P. Damrongsak	S			3244HTD03268	
APPD. T. Shimozone					

枠番 FRAME SIZE VTFOAL-FF350 (180L)