

三相誘導電動機 THREE-PHASE INDUCTION MOTOR

出力 OUTPUT	形 TYPE	式 FORM	定 格 RATING	電 圧 VOLTAGE (V)	周波数 FREQ. (Hz)	同期回転速度 SYNC. SPEED (min ⁻¹)	極 数 POLES	耐熱クラス TH. CLASS	質 量 MASS (kg)
15HP	VTFOA	LKK	S1	380/415	50	3000	2	F	96
20HP	VTFOA	LKK	S1	380/415	50	3000	2	F	105
15HP	VTFOA	LKK	S1	380/415	50	1500	4	F	105
10HP	VTFOA	LKK	S1	380/415	50	1000	6	F	97

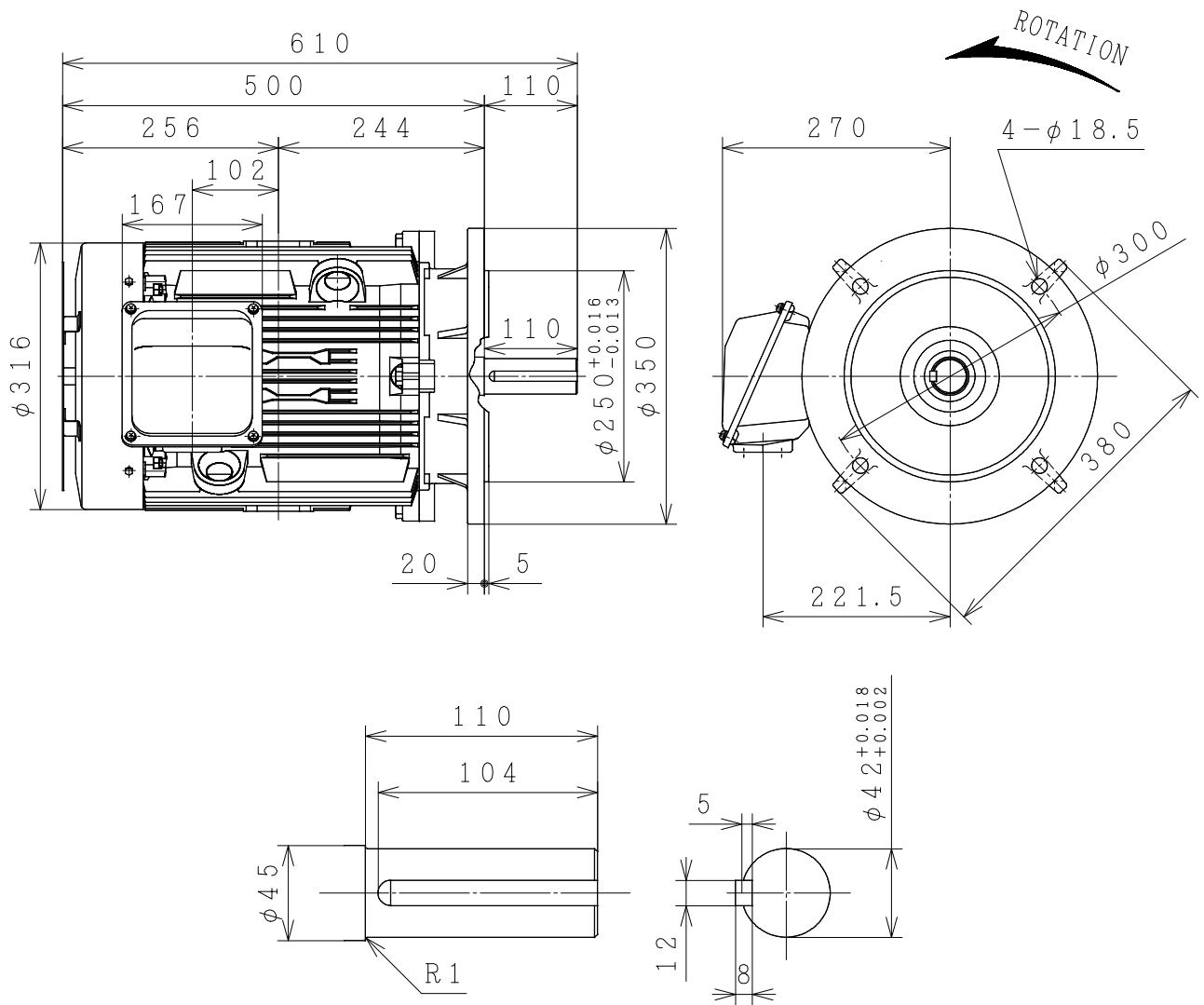

PROTECTION : IP55

保護方式 (PROTECTION)		塗装色 (COLOR)	
軸受 (BRG.)	反負荷側 (O. S.)	負荷側 (D. S.)	
用途 USE		付属品 ACCESSORY	
備考 NOTICE			
御注文主 CUSTOMER		数量 QTY.	受注番号 ORDER NO.
		作業番号 WORK NO.	REV.
DWN. C. Saknarin	05-Oct-2015	寸 法 図 DIMENSIONS	
CHKD. P. Damrongsak			
APPD. T. Shimozone			
枠 番 FRAME SIZE VTFOAL-FF300 (160M)		HITACHI Hitachi Industrial Technology (Thailand), Ltd.	
		NARASHINO DWG. NO. 3244HTD03256	
		SH.	